

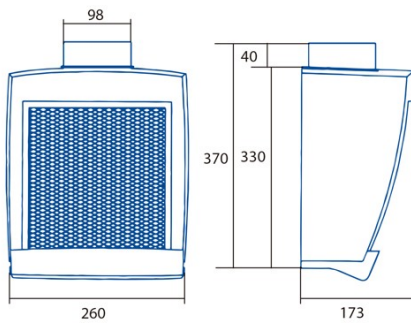

PROFESSIONAL 500 GW

Cod. 00117400

EAN 8422248010832



INFORMACIÓN GENERAL

EAN/UPC	8422248010832
Subfamily	Kitchen Extractor

Product fiche according to directives EU65/2014 - EN61591, EN60704-2-13, EN50564

AEC (Energy consumption per year) (kWh/año)	60
EEL class (Energy efficiency class)	D
FDE (Fluid dynamic efficiency)	8
FDE class (Fluid dynamic efficiency class)	E
LE class (Light efficiency class)	N_A
GFE (Grease filtering efficiency)	51,9
GFE Class (Grease filtering efficiency class)	F
Normal mode airflow MAX (m3/h)	450
Normal mode acoustic power MAX (dB)	57
Po (Off-mode power consumption) (W)	0
Ps (Stand-by power consumption) (W)	0

Integration directive EU 66/2014

f (Factor Increase in the time)	1,8
EEL (Energy efficiency Index)	90
QBEP (Maximum airflow point efficiency) (m3/h)	145,3
PBEP (Maximum pressure point efficiency) (Pa)	152,5
WBEP (Electrical power consumption at maximum efficiency) (W)	94,5

External Dimensions

Width (mm)	260
Depth (mm)	173
Minimum Total Height (mm)	650
Outlet Diameter (mm)	98

Characteristics

Motor Quantity	1
Maximum Pressure (Pa)	235
Free Outlet Airflow (m3/h)	450
Filter Technology	Malla
Booster	-
Timer	-
Filter Saturation Indicator	-
Charcoal Filter Change Indicator	-
Remote control	-

Installation

Minimum distance to an electric cooktop (mm)	65
Minimum distance to a gas cooktop (mm)	650
Recirculation Option	-
Charcoal Filter	-
Back Draught Shutter	-
Inner shield	-

Electric Connection

Rated voltage (V)	230
Rated frequency (Hz)	50
Rated power input (W)	125
Protection against electric shock	Class II
Power cord length (m)	0,5
Plug type	No plug

Accessories

Upper Decorative Duct Extension	N_A
White Decorative Duct	N_A

Black Decorative Duct	N_A
Island Tube Enhancer	N_A
Back Draught Shutter	N_A
MAX PRO Metal Filter	N_A
Active Charcoal Filter	1140800
Noiseless Flexible Duct	N_A
Recirculating kit	N_A