

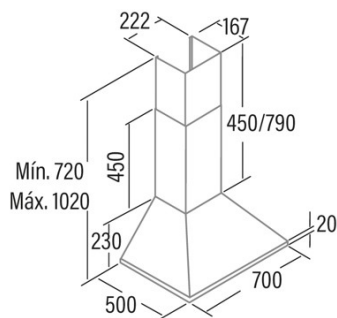

# OMEGA 700 WH

Cod. **02003010**

EAN **8422248190626**



## INFORMACIÓN GENERAL

EAN/UPC	8422248190626
Subfamily	Chimney

### Product fiche according to directives EU65/2014 - EN61591, EN60704-2-13, EN50564

AEC (Energy consumption per year) (kWh/año)	95,4
EEL class (Energy efficiency class)	C
FDE (Fluid dynamic efficiency)	17,8
FDE class (Fluid dynamic efficiency class)	D
LE (Light efficiency) (lux/W)	26
LE class (Light efficiency class)	B
GFE (Grease filtering efficiency)	90,3
GFE Class (Grease filtering efficiency class)	B
Normal mode airflow MIN (m3/h)	385
Normal mode airflow MAX (m3/h)	645
Normal mode acoustic power MIN (dB)	57,8
Normal mode acoustic power MAX (dB)	71,8
Po (Off-mode power consumption) (W)	0
Ps (Stand-by power consumption) (W)	0

### Integration directive EU 66/2014

f (Factor Increase in the time)	1,4
EEL (Energy efficiency Index)	81,3
QBEP (Maximum airflow point efficiency) (m3/h)	371,8
PBEP (Maximum pressure point efficiency) (Pa)	314
WBEP (Electrical power consumption at maximum efficiency) (W)	182,5
WL (Rated power lighting system) (W)	3
EMIDDLE (Average illuminance on the cooking surface) (lux)	78

### External Dimensions

Width (mm)	700
Depth (mm)	500
Maximum Total Height (mm)	1020
Minimum Total Height (mm)	720
Outlet Diameter (mm)	150, 125

### Characteristics

Motor Quantity	1
Motor Model	TA
Maximum Pressure (Pa)	430
Filter Technology	Aluminium mesh
Control Technology	Mechanical push button
Booster	-
Power levels	3
Timer	-
Filter Saturation Indicator	-
Charcoal Filter Change Indicator	-
Dimmer Function	-
Connectivity	-
Remote control	-
Display	-

### Lighting

Light Model	CSLED
Lightning Technology	LED

### Installation

Minimum distance to an electric cooktop (mm)	650
Minimum distance to a gas cooktop (mm)	650
Recirculation Option	√

Charcoal Filter	-
Back Draught Shutter	-
Inner shield	-

---

#### **Electric Connection**

Rated voltage (V)	220-240
Rated frequency (Hz)	50
Rated power input (W)	273
Protection against electric shock	Class II
Power cord length (m)	0,7
Plug type	No plug

---

#### **Accessories**

Upper Decorative Duct Extension	02862001
White Decorative Duct	No
Black Decorative Duct	No
Island Tube Enhancer	No
Back Draught Shutter	02832001
MAX PRO Metal Filter	02800917
Active Charcoal Filter	02859391
Noiseless Flexible Duct	02893002
Recirculating kit	02894000

---