

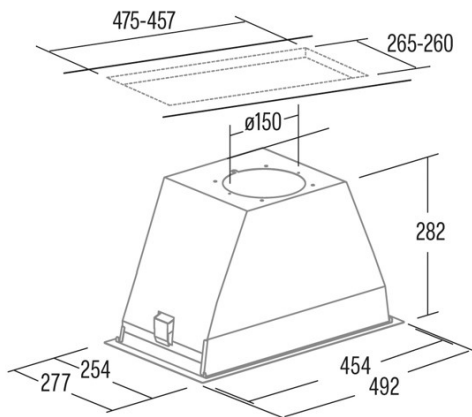

GT-PLUS 45 X

Cod. **02030309**

EAN **8422248190374**



INFORMACIÓN GENERAL

EAN/UPC	8422248190374
Subfamily	Insert

Product fiche according to directives EU65/2014 - EN61591, EN60704-2-13, EN50564

AEC (Energy consumption per year) (kWh/año)	886
EEl class (Energy efficiency class)	C
FDE (Fluid dynamic efficiency)	163
FDE class (Fluid dynamic efficiency class)	D
LE (Light efficiency) (lux/W)	292
LE class (Light efficiency class)	A
GFE (Grease filtering efficiency)	912
GFE Class (Grease filtering efficiency class)	B
Normal mode airflow MIN (m3/h)	300
Normal mode airflow MAX (m3/h)	645
Normal mode acoustic power MIN (dB)	50
Normal mode acoustic power MAX (dB)	65
Po (Off-mode power consumption) (W)	0
Ps (Stand-by power consumption) (W)	0

Integration directive EU 66/2014

f (Factor Increase in the time)	1,4
EEl (Energy efficiency Index)	811
QBEP (Maximum airflow point efficiency) (m3/h)	358,1
PBEP (Maximum pressure point efficiency) (Pa)	270
WBEP (Electrical power consumption at maximum efficiency) (W)	164,9
WL (Rated power lighting system) (W)	6
EMIDDLE (Average illuminance on the cooking surface) (lux)	202

External Dimensions

Width (mm)	492
Depth (mm)	277
Maximum Total Height (mm)	282
Minimum Total Height (mm)	282
Outlet Diameter (mm)	150, 125

Characteristics

Motor Quantity	1
Motor Model	BT2
Maximum Pressure (Pa)	400
Filter Technology	Aluminium mesh
Control Technology	Mechanical push button
Booster	-
Power levels	3
Timer	-
Filter Saturation Indicator	-
Charcoal Filter Change Indicator	-
Dimmer Function	-
Connectivity	-
Remote control	-
Display	-

Lighting

Light Model	CSLED
Lightning Technology	LED

Installation

Minimum distance to an electric cooktop (mm)	550
Minimum distance to a gas cooktop (mm)	650
Recirculation Option	√

Charcoal Filter	-
Back Draught Shutter	-
Inner shield	-

Electric Connection

Rated voltage (V)	220-240
Rated frequency (Hz)	50
Rated power input (W)	206
Protection against electric shock	Class II
Power cord length (m)	15
Plug type	Type C

Accessories

Back Draught Shutter	02832004
Active Charcoal Filter	02859398
Noiseless Flexible Duct	02893002
