

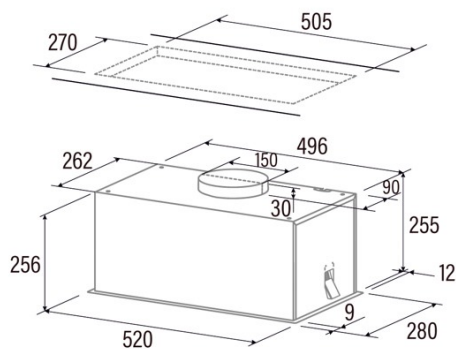

GPL 52 X

Cod. **02030304**

EAN **8422248198479**



GENERAL INFORMATION

EAN/UPC	8422248198479
Subfamily	Insert

Product sheet according to directives EU65/2014 - EN61591, EN60704-2-13, EN50564

AEC (Annual energy consumption) (kWh/year)	62,2
EEl class (energy efficiency class)	B
FDE (fluid dynamic efficiency)	22,2
FDE class (fluid dynamic efficiency class)	C
LE (light efficiency) (lux/W)	30,2
LE class (light efficiency class)	A
GFE (grease filtering efficiency)	66,3
GFE class (grease filtering efficiency class)	D
Airflow in normal mode MIN (m3/h)	235
Airflow in normal mode MAX (m3/h)	529
Acoustic power in normal mode MIN (dB)	48
Acoustic power in normal mode MAX (dB)	68
Po (energy consumption in off mode) (W)	0
Ps (energy consumption in standby mode) (W)	0

Integration directive EU 66/2014

f (time increase factor)	1,2
EEl (Energy Efficiency Index)	68,7
QBEP (maximum efficiency at air flow point) (m3/h)	295,5
PBEP (maximum efficiency at pressure point) (Pa)	360
WBEP (power consumption at maximum efficiency) (W)	132,9
WL (nominal power lighting system) (W)	121
EMIDDLE (Average illuminance on the cooking surface) (lux)	4

Characteristics

Motor quantity	1
Maximum pressure (Pa)	482
Filter technology	Aluminium mesh
Control technology	Electronic Soft Touch
Power levels	3

Lighting

Light model	ECOLED STRIP
Ray technology	LED

Electric connection

Nominal voltage (V)	220-240
Nominal frequency (Hz)	50
Nominal input power (W)	192
Electric shock protection	Class I
Power cord length (m)	1,2
Plug type	No plug