

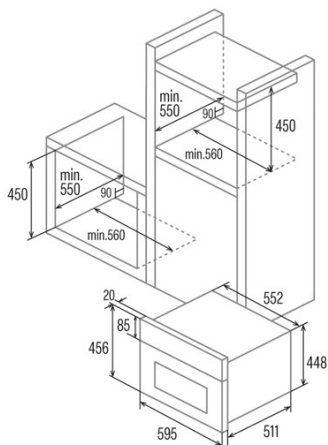

MD 5008 WH

Cod. **07003000**

EAN **8422248067898**

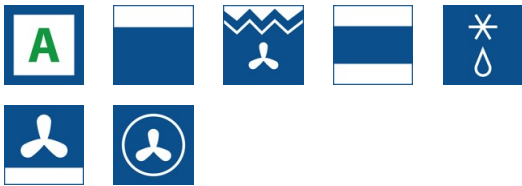

GENERAL INFORMATION

EAN/UPC	8422248067898
Subfamily	Compact

Product sheet

Energy Efficiency Index (EEI)	97,2
Energy efficiency class	A
Energy consumption in conventional mode (kWh/cycle)	0,7
Energy consumption in fan mode (kWh/cycle)	0,71
Heat source	Electricity
Appliance mass [Kg]	30,4
Number of cavities	1
Cavity volume (L)	40

Dimensions

Width (mm)	456
Depth (mm)	466
Built-in width (mm)	560
Built-in height (mm)	450
Built-in depth (mm)	550

Controls

Control type	Touch control
Display	LCD
Number of functions	8
Functions	Light;Defrosting;Double grill with fan;Top heating;Top and bottom heating;Top and bottom heating with fan;Bottom heating with fan;Turbo heating
Timer	Electronic
On/off indicator	√
Thermostat indicator	194
Minimum temperature [°C]	MC2330002
Maximum temperature [°C]	250

Characteristics

Cleaning	Aquasmart Manual
Enamel	Black
Removable inner glass	-
Number of light bulbs	25
Bulb power [W]	1
Number of door glasses	344,28
Manual door lock	-
Side racks	√
Levels	4
Telescopic guides	0,75
Convection fan	√

Safety

Cooling fan	√
Overheating protection	1000
Automatic safety shutdown	√
Pyrolysis door lock	-
Pyrolysis lock indicator	-

Electrical connection

Lower power of the heating element [W]	1300
Nominal voltage (V)	220-240
Nominal frequency (Hz)	50/60
Nominal input power (W)	2380
Electric shock protection	80

Power cord length (m)	1
Plug type	No plug

Accessories

Deep tray	√
Steam tray	-
Grill	truety Document
Inner grill	Built-in
Telescopic guides	√
Tray handle	Lifestyle
Removable tank	-
Pizza stone	-
Roast kit	Energy Fiche
