

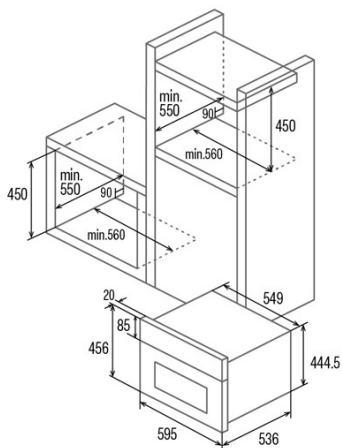

CMD 5007 X

Cod. 07003002

EAN 8422248372886



GENERAL INFORMATION

EAN/UPC	8422248372886
Subfamily	Turbo

Product sheet

Energy Efficiency Index (EEI)	97,2
Energy efficiency class	A
Energy consumption in conventional mode (kWh/cycle)	0,76
Heat source	Electricity
Number of cavities	1
Cavity volume (L)	44

Dimensions

Width (mm)	595
Depth (mm)	536

Controls

Control type	Mechanical
Number of functions	7
Functions	Grill;Top and bottom heating;Double Grill;Double grill with fan;Bottom heating with fan;Top and bottom heating with fan

Characteristics

Cleaning	Pirolisis
Enamel	Pyrolytic
Light type	LED
Bulb power [W]	1
Number of door glasses	3

Electrical connection

Turbocharger power [W]	2380
Microwave power [W]	2000
Nominal voltage (V)	220-240
Nominal frequency (Hz)	50/60

Accessories

Deep tray	√
-----------	---