

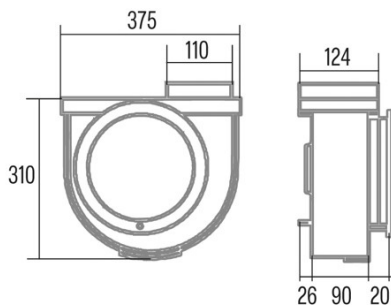

GS-600

Cod. 00116002

EAN 8422248100601



GENERAL INFORMATION

EAN/UPC	8422248100601
Subfamily	Kitchen Extractor

Product sheet according to directives EU65/2014 - EN61591, EN60704-2-13, EN50564

AEC (Annual energy consumption) (kWh/year)	51,7
EEl class (energy efficiency class)	C
FDE (fluid dynamic efficiency)	12,5
FDE class (fluid dynamic efficiency class)	E
LE class (light efficiency class)	N_A
GFE class (grease filtering efficiency class)	N_A
Airflow in normal mode MAX (m3/h)	480
Acoustic power in normal mode MAX (dB)	50
Po (energy consumption in off mode) (W)	0
Ps (energy consumption in standby mode) (W)	0

Integration directive EU 66/2014

f (time increase factor)	1,6
EEl (Energy Efficiency Index)	78,9
QBEP (maximum efficiency at air flow point) (m3/h)	311,7
PBEP (maximum efficiency at pressure point) (Pa)	131,6
WBEP (power consumption at maximum efficiency) (W)	91,4

External Dimensions

Width (mm)	375
Depth (mm)	136
Minimum total height (mm)	650
Diamètre de sortie (mm)	110

Characteristics

Motor quantity	1
Maximum pressure (Pa)	200
Free out airflow (m3/h)	480
Booster	-
Timer	-
Charcoal filter replacement indicator	-
Remote control	-

Installation

Minimum distance to electric plate (mm)	65
Minimum distance to gas plate (mm)	650
Recirculation option	-
Charcoal filter	-
Back draught shutter	-
Inner shield	-

Electric connection

Nominal voltage (V)	230
Nominal frequency (Hz)	50
Nominal input power (W)	105
Electric shock protection	Class I
Power cord length (m)	0,5
Plug type	No plug

Accessories

Upper decorative duct extension	N_A
White decorative duct	N_A
Black decorative duct	N_A
Island tube booster	N_A
Back draught shutter	N_A
MAX PRO Metal filter	N_A

Activated charcoal filter	N_A
Noiseless flexible duct	N_A
Recirculation kit	N_A