

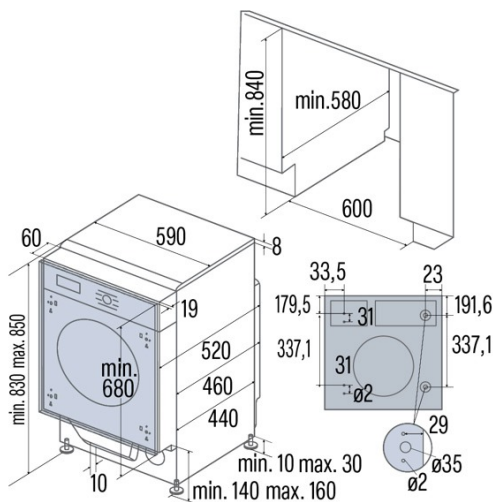

LI 08015

Cod. 07900005

EAN 8422248360302



GENERAL INFORMATION

EAN/UPC	8422248360302
Subfamily	Washing Machine

Product sheet

Assigned capacity [kg]	8
Energy efficiency class	A
Airborne acoustic noise emissions during spinning [dB(A)]	72
Installation type	Built-In

Control

Control type	Knob + Soft Touch Buttons
Display	LED
Wash temperature selector	√
Spin speed selector	√
Start delay	1-24h
Remaining time indicator	√
Start/Pause	√

Programming

Number of programmes	16
Programme 1 - Name	Cotton
Programme 2 - Name	Sintetic
Programme 3 - Name	Delicates
Programme 4 - Name	ECO
Programme 5 - Name	Wool
Programme 6 - Name	Hand wash
Programme 7 - Name	Quick
Programme 8 - Name	Mix
Programme 9 - Name	Sport clothes
Programme 10 - Name	Baby clothes
Programme 11 - Name	Customized
Programme 12 - Name	20°C
Programme 13 - Name	Jeans
Programme 14 - Name	Spin only
Programme 15 - Name	Rinse and spin
Programme 16 - Name	Bulky
Pre-wash function	√
Extra rinse function	√
Add clothes function	√
Automatic cleaning function	√

General features

Child lock	√
Inlet water protection	√
Overflow protection	√
Overheating protection	√

Power connection

Nominal voltage (V)	220-240
Nominal frequency (Hz)	50
Nominal input power (W)	1950
Plug type	Type F
Inlet water hose length (m)	1
Drainage water hose length (m)	1,6

Installation

Width (mm)	590
Min. height (mm)	825
Max. height (mm)	845
Depth (mm)	545
Adjustable height	√

Built-in width (mm)	600
Inner height (mm)	840
Built-in depth (mm)	580