

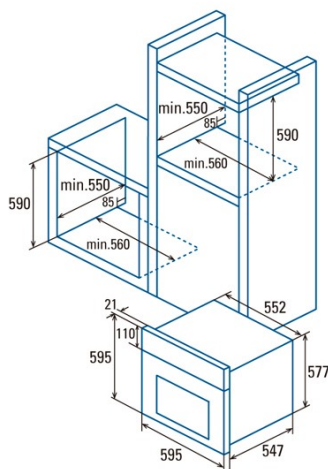

MT 8012 WH

Cod. 07002412

EAN 8422248094016



GENERAL INFORMATION

EAN/UPC	8422248094016
Subfamily	Turbo

Product sheet

Energy Efficiency Index (EEI)	86,6
Energy efficiency class	A
Energy consumption in conventional mode (kWh/cycle)	0,71
Energy consumption in fan mode (kWh/cycle)	0,81
Heat source	Electricity
Appliance mass [Kg]	39,5
Number of cavities	1
Cavity volume (L)	72

Dimensions

Width (mm)	595
Height (mm)	595
Depth (mm)	568
Built-in width (mm)	560
Built-in height (mm)	590
Built-in depth (mm)	550

Controls

Control type	Touch control
Display	LCD
Number of functions	12
Functions	Turbo_heating;Grill;Double Grill;Bottom heating;Top and bottom heating with fan;Bottom heating with fan;Fast preheat;Double grill with fan;Defrosting;Light;Top and bottom heating
Timer	Electronic
On/off indicator	√
Thermostat indicator	√
Minimum temperature [°C]	50
Maximum temperature [°C]	250
Thermal probe	-

Characteristics

Cleaning	Aquasmart Automatic
Enamel	Black
Drop down grill	-
Removable inner glass	√
Number of light bulbs	25
Bulb power [W]	1
Number of door glasses	3
Manual door lock	-
Soft close	√
Cavity type	Flat
Side racks	√
Levels	5
Telescopic guides	1
Convection fan	√

Safety

Cooling fan	√
Overheating protection	√
Automatic safety shutdown	√
Pyrolysis door lock	-
Pyrolysis lock indicator	-

Electrical connection

Power of the upper heating element [W]	900
Lower power of the heating element [W]	1100
Turbocharger power [W]	2000
Nominal voltage (V)	220-240
Nominal frequency (Hz)	50/60
Nominal input power (W)	2380
Electric shock protection	Class I
Power cord length (m)	1
Plug type	No plug

Accessories

Flat tray	√
Deep tray	√
Steam tray	-
Grill	√
Inner grill	-
Telescopic guides	√
Tray handle	-
Removable tank	-
Pizza stone	-
Roast kit	-