

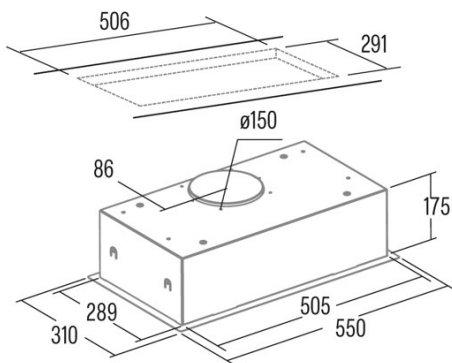

GCB 55 X

Cod. 02030300

EAN 8422248108454



GENERAL INFORMATION

EAN/UPC	8422248108454
Subfamily	Insert

Product sheet according to directives EU65/2014 - EN61591, EN60704-2-13, EN50564

AEC (Annual energy consumption) (kWh/year)	54
EEl class (energy efficiency class)	C
FDE (fluid dynamic efficiency)	10,1
FDE class (fluid dynamic efficiency class)	E
LE (light efficiency) (Lux/W)	30,4
LE class (light efficiency class)	A
GFE (grease filtering efficiency)	58,3
GFE class (grease filtering efficiency class)	E
Airflow in normal mode MIN (m3/h)	282
Airflow in normal mode MAX (m3/h)	371,1
Acoustic power in normal mode MIN (dB)	59
Acoustic power in normal mode MAX (dB)	65,9
Po (energy consumption in off mode) (W)	0

Integration directive EU 66/2014

<i>f</i> (time increase factor)	1,64
EEl (Energy Efficiency Index)	83,6
QBEP (maximum efficiency at air flow point) (m3/h)	197,5
PBEP (maximum efficiency at pressure point) (Pa)	161
WBEP (power consumption at maximum efficiency) (W)	87,2
WL (nominal power lighting system) (W)	3
EMIDDLE (Average illuminance on the cooking surface) (lux)	91,2

External Dimensions

Width (mm)	550
Depth (mm)	310
Maximum total height (mm)	187
Minimum total height (mm)	187
Diamètre de sortie (mm)	150, 125

Characteristics

Motor quantity	1
Maximum pressure (Pa)	226
Filter technology	Aluminium mesh
Control technology	Mechanical push button
Booster	-
Power levels	3
Timer	-
Filter saturation indicator	-
Charcoal filter replacement indicator	-
Dimmer function	-
Connectivity	No
Remote control	-
Display	-

Lighting

Light model	CSLED
Ray technology	LED

Installation

Minimum distance to electric plate (mm)	550
Minimum distance to gas plate (mm)	650
Recirculation option	√
Charcoal filter	-
Back draught shutter	Included
Inner shield	-

Electric connection

Nominal voltage (V)	220-240
Nominal frequency (Hz)	50
Nominal input power (W)	123
Electric shock protection	Class I

Accessories

Activated charcoal filter	02859500
Noiseless flexible duct	02893002