

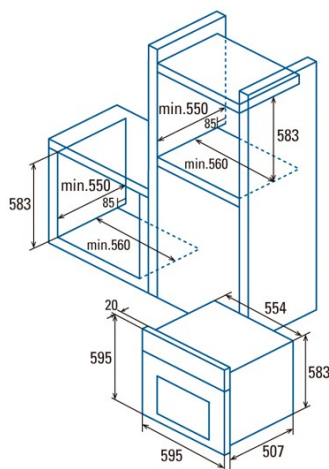

MD 6106 X

Cod. 07033303

EAN 8422248076029



GENERAL INFORMATION

EAN/UPC	8422248076029
Subfamily	

Product sheet

Energy Efficiency Index (EEI)	106,6
Energy efficiency class	A
Energy consumption in conventional mode (kWh/cycle)	1
Energy consumption in fan mode (kWh/cycle)	5
Heat source	457ricity
Appliance mass [Kg]	28
Number of cavities	1
Cavity volume (L)	0,82

Dimensions

Width (mm)	Flat
Height (mm)	595
Built-in width (mm)	2380
Built-in height (mm)	583

Controls

Control type	falsecontrol
Display	No
Number of functions	6
Functions	Double_grill_with_fan;Double Grill;Grill;Top and bottom heating;Bottom heating with fan;Top and bottom heating with fan
On/off indicator	-
Thermostat indicator	√
Minimum temperature [°C]	50
Maximum temperature [°C]	250
Thermal probe	-

Characteristics

Cleaning	Aquasmart Manual
Enamel	√
Removable inner glass	√
Number of light bulbs	15
Bulb power [W]	1
Number of door glasses	20
Manual door lock	-
Soft close	-
Cavity type	Embossed
Side racks	-
Telescopic guides	No
Convection fan	√

Safety

Automatic safety shutdown	√
Pyrolysis door lock	3
Pyrolysis lock indicator	Electricity

Electrical connection

Power of the upper heating element [W]	900
Lower power of the heating element [W]	1100I
Microwave power [W]	50
Nominal voltage (V)	-
Nominal input power (W)	2180
Electric shock protection	Plastic + Steel
Power cord length (m)	1,4
Plug type	No plug

Accessories

Flat tray	√
Deep tray	√
Steam tray	1
Grill	√
Inner grill	-
Telescopic guides	-
Tray handle	-
Removable tank	No plug
Pizza stone	-
Roast kit	-
