

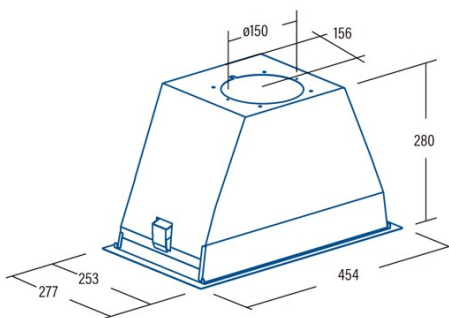

GT-PLUS 45 X /L

Cod. 02030307

EAN 8422248087346



GENERAL INFORMATION

EAN/UPC	8422248087346
Subfamily	Insert

Product sheet according to directives EU65/2014 - EN61591, EN60704-2-13, EN50564

AEC (Annual energy consumption) (kWh/year)	90,3
EEL class (energy efficiency class)	C
FDE class (fluid dynamic efficiency class)	D
LE (light efficiency) (Lux/W)	24,3
LE class (light efficiency class)	B
GFE (grease filtering efficiency)	91,2
GFE class (grease filtering efficiency class)	B
Airflow in normal mode MIN (m3/h)	300
Acoustic power in normal mode MAX (dB)	65
Ps (energy consumption in standby mode) (W)	0

Integration directive EU 66/2014

f (time increase factor)	69
QBEP (maximum efficiency at air flow point) (m3/h)	390
PBEP (maximum efficiency at pressure point) (Pa)	270
WL (nominal power lighting system) (W)	7

External Dimensions

Width (mm)	492
Depth (mm)	600
Maximum total height (mm)	280
Minimum total height (mm)	-
Diamètre de sortie (mm)	150, 125

Characteristics

Motor quantity	1
Filter technology	Aluminium mesh
Booster	-
Power levels	300004
Timer	-
Filter saturation indicator	-
Charcoal filter replacement indicator	107
Dimmer function	-
Connectivity	-

Lighting

Light model	EcoLed
Ray technology	Detail

Installation

Minimum distance to electric plate (mm)	550
Minimum distance to gas plate (mm)	650
Recirculation option	√
Charcoal filter	44,5
Back draught shutter	rocker_switch
Inner shield	-

Electric connection

Nominal voltage (V)	220-240
Nominal frequency (Hz)	50
Electric shock protection	Cassette
Power cord length (m)	1,5
Plug type	Type CTION

Accessories

Upper decorative duct extension	A
---------------------------------	---

White decorative duct	No
Black decorative duct	No
Island tube booster	No
Back draught shutter	2832004
MAX PRO Metal filter	No
Activated charcoal filter	2859398
Noiseless flexible duct	LED
Recirculation kit	No