

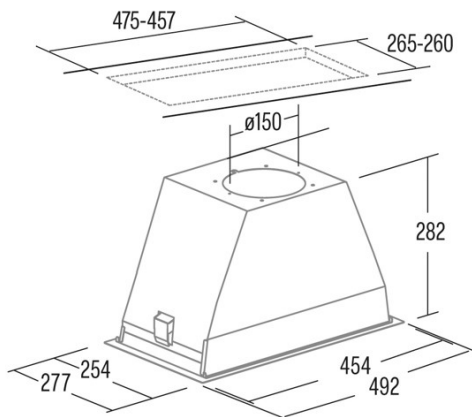

# GT-PLUS 45 BK

Cod. **02030408**

EAN **8414600000**



## INFORMACIÓN GENERAL

EAN/UPC	8414600000
Subfamily	Insert

### Product fiche according to directives EU65/2014 - EN61591, EN60704-2-13, EN50564

AEC (Energy consumption per year) (kWh/año)	886
EEl class (Energy efficiency class)	C
FDE (Fluid dynamic efficiency)	163
FDE class (Fluid dynamic efficiency class)	D
LE (Light efficiency) (lux/W)	292
LE class (Light efficiency class)	A
GFE (Grease filtering efficiency)	912
GFE Class (Grease filtering efficiency class)	B
Normal mode airflow MIN (m3/h)	300
Normal mode airflow MAX (m3/h)	645
Normal mode acoustic power MIN (dB)	50
Normal mode acoustic power MAX (dB)	65
Po (Off-mode power consumption) (W)	0
Ps (Stand-by power consumption) (W)	0

### Integration directive EU 66/2014

f (Factor Increase in the time)	1,4
EEl (Energy efficiency Index)	811
QBEP (Maximum airflow point efficiency) (m3/h)	358,1
PBEP (Maximum pressure point efficiency) (Pa)	270
WBEP (Electrical power consumption at maximum efficiency) (W)	164,9
WL (Rated power lighting system) (W)	6
EMIDDLE (Average illuminance on the cooking surface) (lux)	202

### External Dimensions

Width (mm)	492
Depth (mm)	277
Maximum Total Height (mm)	282
Minimum Total Height (mm)	282
Outlet Diameter (mm)	150, 125

### Characteristics

Motor Quantity	1
Motor Model	BT2
Maximum Pressure (Pa)	400
Filter Technology	Aluminium mesh
Control Technology	Mechanical push button
Booster	-
Power levels	3
Timer	-
Filter Saturation Indicator	-
Charcoal Filter Change Indicator	-
Dimmer Function	-
Connectivity	No
Remote control	-
Display	-

### Lighting

Light Model	SSLED
Lightning Technology	LED

### Installation

Minimum distance to an electric cooktop (mm)	550
Minimum distance to a gas cooktop (mm)	650
Recirculation Option	√

Charcoal Filter	-
Back Draught Shutter	-
Inner shield	-

---

**Electric Connection**

Rated voltage (V)	220-240
Rated frequency (Hz)	50
Rated power input (W)	206
Protection against electric shock	Class II
Power cord length (m)	15
Plug type	Type C

---

**Accessories**

Back Draught Shutter	02832004
Active Charcoal Filter	02859398
Noiseless Flexible Duct	02893002

---