

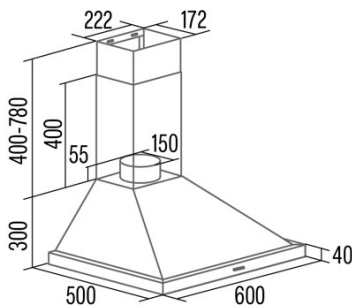

BETA PRO 6000 X

Cod. **02075418**

EAN **8422248371537**



INFORMACIÓN GENERAL

| | |
|-----------|---------------|
| EAN/UPC | 8422248371537 |
| Subfamily | Chimney |

Product fiche according to directives EU65/2014 - EN61591, EN60704-2-13, EN50564

| | |
|---|------|
| AEC (Energy consumption per year) (kWh/año) | 63,5 |
| EEl class (Energy efficiency class) | A |
| FDE (Fluid dynamic efficiency) | 29,2 |
| FDE class (Fluid dynamic efficiency class) | A |
| LE (Light efficiency) (lux/W) | 33 |
| LE class (Light efficiency class) | A |
| GFE (Grease filtering efficiency) | 75,2 |
| GFE Class (Grease filtering efficiency class) | C |
| Normal mode airflow MIN (m3/h) | 441 |
| Normal mode airflow MAX (m3/h) | 621 |
| Boost mode airflow (m3/h) | 990 |
| Normal mode acoustic power MIN (dB) | 65 |
| Normal mode acoustic power MAX (dB) | 71 |
| Boost mode acoustic power (dB) | 75 |
| Po (Off-mode power consumption) (W) | 0 |
| Ps (Stand-by power consumption) (W) | 0,48 |

Integration directive EU 66/2014

| | |
|---|-------|
| f (Factor Increase in the time) | 0,9 |
| EEl (Energy efficiency Index) | 53,5 |
| QBEP (Maximum airflow point efficiency) (m3/h) | 457,9 |
| PBEP (Maximum pressure point efficiency) (Pa) | 422 |
| WBEP (Electrical power consumption at maximum efficiency) (W) | 183,9 |
| WL (Rated power lighting system) (W) | 4,2 |
| EMIDDLE (Average illuminance on the cooking surface) (lux) | 140,4 |

Characteristics

| | |
|-----------------------|--------------------------------------|
| Motor Quantity | 1 |
| Motor Model | A1000 |
| Maximum Pressure (Pa) | 473,39 |
| Filter Technology | Aluminium mesh |
| Control Tecnology | PANEL ELECTRONICO DISPLAY DIGITAL |
| Booster | √ |
| Power levels | 3 |
| Timer | √ |
| Display | Display |

Lighting

| | |
|----------------------|--------|
| Light Model | ECOLED |
| Lightning Technology | LED |

Electric Connection

| | |
|-----------------------------------|---------|
| Rated voltage (V) | 220-240 |
| Rated frequency (Hz) | 50 |
| Rated power input (W) | 383 |
| Protection against electric shock | Class I |
| Power cord length (m) | 1,2 |
| Plug type | Type F |

Accessories

| | |
|----------------------|----------|
| Back Draught Shutter | 02800706 |
|----------------------|----------|

