

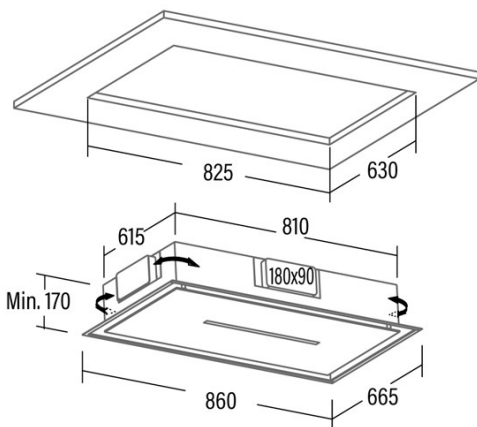

ISLA BENNU SLIM 900 X

Cod. **02111308**

EAN **8422248110891**

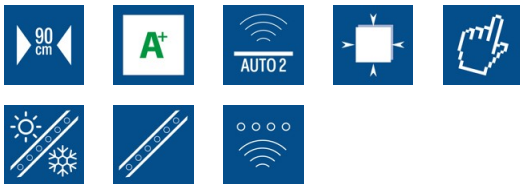

INFORMACIÓN GENERAL

EAN/UPC	8422248110891
Subfamily	Ceiling

Product fiche according to directives EU65/2014 - EN61591, EN60704-2-13, EN50564

AEC (Energy consumption per year) (kWh/año)	44,1
EEL class (Energy efficiency class)	B
FDE (Fluid dynamic efficiency)	25,2
FDE class (Fluid dynamic efficiency class)	B
LE (Light efficiency) (lux/W)	23,7
LE class (Light efficiency class)	B
GFE (Grease filtering efficiency)	91,2
GFE Class (Grease filtering efficiency class)	B
Normal mode airflow MIN (m3/h)	300
Normal mode airflow MAX (m3/h)	500
Boost mode airflow (m3/h)	620
Normal mode acoustic power MIN (dB)	50
Normal mode acoustic power MAX (dB)	65
Boost mode acoustic power (dB)	67
Po (Off-mode power consumption) (W)	0,3
Ps (Stand-by power consumption) (W)	0

Integration directive EU 66/2014

f (Factor Increase in the time)	1,1
EEL (Energy efficiency Index)	60,7
QBEP (Maximum airflow point efficiency) (m3/h)	326,9
PBEP (Maximum pressure point efficiency) (Pa)	269,4
WBEP (Electrical power consumption at maximum efficiency) (W)	97,1
WL (Rated power lighting system) (W)	7
EMIDDLE (Average illuminance on the cooking surface) (lux)	166

External Dimensions

Width (mm)	860
Depth (mm)	665
Maximum Total Height (mm)	170
Minimum Total Height (mm)	170
Outlet Diameter (mm)	180x90

Characteristics

Motor Quantity	1
Motor Model	S6
Maximum Pressure (Pa)	470
Filter Technology	Aluminium mesh
Control Technology	Electronic Touch Control
Booster	√
Power levels	4
Timer	√
Filter Saturation Indicator	-
Charcoal Filter Change Indicator	-
Dimmer Function	√
Connectivity	√
Remote control	√
Display	Display

Lighting

Light Model	ECOLED
Lightning Technology	LED

Installation

Minimum distance to an electric cooktop (mm)	550
--	-----

Minimum distance to a gas cooktop (mm)	650
Recirculation Option	√
Charcoal Filter	√
Back Draught Shutter	No
Inner shield	-

Electric Connection

Rated voltage (V)	220-240
Rated frequency (Hz)	50
Rated power input (W)	112
Protection against electric shock	Class I

Accessories

Active Charcoal Filter	02800922
------------------------	----------
