

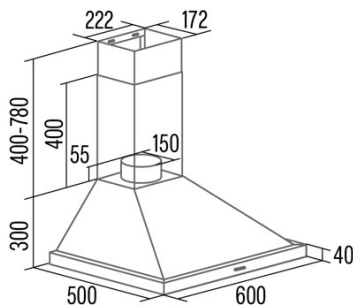

# BETA PRO 6000 X

Cod. 02075418

EAN 8422248371537



## INFORMACIÓN GENERAL

EAN/UPC	8422248371537
Subfamily	Chimney

### Product fiche according to directives EU65/2014 - EN61591, EN60704-2-13, EN50564

AEC (Energy consumption per year) (kWh/año)	63,5
EEl class (Energy efficiency class)	A
FDE (Fluid dynamic efficiency)	29,2
FDE class (Fluid dynamic efficiency class)	A
LE (Light efficiency) (lux/W)	33
LE class (Light efficiency class)	A
GFE (Grease filtering efficiency)	75,2
GFE Class (Grease filtering efficiency class)	C
Normal mode airflow MIN (m3/h)	441
Normal mode airflow MAX (m3/h)	621
Boost mode airflow (m3/h)	990
Normal mode acoustic power MIN (dB)	65
Normal mode acoustic power MAX (dB)	71
Boost mode acoustic power (dB)	75
Po (Off-mode power consumption) (W)	0
Ps (Stand-by power consumption) (W)	0,48

### Integration directive EU 66/2014

f (Factor Increase in the time)	0,9
EEl (Energy efficiency Index)	53,5
QBEP (Maximum airflow point efficiency) (m3/h)	457,9
PBEP (Maximum pressure point efficiency) (Pa)	422
WBEP (Electrical power consumption at maximum efficiency) (W)	183,9
WL (Rated power lighting system) (W)	4,2
EMIDDLE (Average illuminance on the cooking surface) (lux)	140,4

### Characteristics

Motor Quantity	1
Motor Model	A1000
Maximum Pressure (Pa)	473,39
Filter Technology	Aluminium mesh
Control Tecnology	PANEL ELECTRONICO DISPLAY DIGITAL
Booster	√
Power levels	3
Timer	√
Display	Display

### Lighting

Light Model	ECOLED
Lightning Technology	LED

### Electric Connection

Rated voltage (V)	220-240
Rated frequency (Hz)	50
Rated power input (W)	383
Protection against electric shock	Class I
Power cord length (m)	1,2
Plug type	Type F

### Accessories

Back Draught Shutter	02800706
----------------------	----------

