

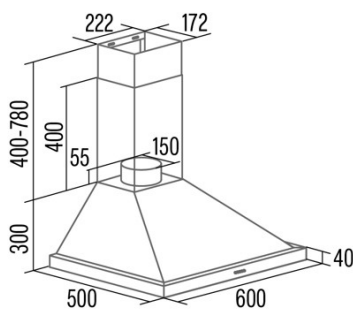

BETA PRO 6000 BK

Cod. 02075421

EAN 8422248371568



INFORMACIÓN GENERAL

EAN/UPC	8422248371568
Subfamily	Chimney

Product fiche according to directives EU65/2014 - EN61591, EN60704-2-13, EN50564

AEC (Energy consumption per year) (kWh/año)	63,5
EEL class (Energy efficiency class)	A
FDE (Fluid dynamic efficiency)	29,2
FDE class (Fluid dynamic efficiency class)	A
LE (Light efficiency) (lux/W)	33
LE class (Light efficiency class)	A
GFE (Grease filtering efficiency)	75,2
GFE Class (Grease filtering efficiency class)	C
Normal mode airflow MIN (m3/h)	441
Normal mode airflow MAX (m3/h)	621
Boost mode airflow (m3/h)	990
Normal mode acoustic power MIN (dB)	65
Normal mode acoustic power MAX (dB)	71
Boost mode acoustic power (dB)	75
Po (Off-mode power consumption) (W)	0
Ps (Stand-by power consumption) (W)	0,48

Integration directive EU 66/2014

f (Factor Increase in the time)	0,9
EEL (Energy efficiency Index)	53,5
QBEP (Maximum airflow point efficiency) (m3/h)	457,9
PBEP (Maximum pressure point efficiency) (Pa)	422
WBEP (Electrical power consumption at maximum efficiency) (W)	183,9
WL (Rated power lighting system) (W)	4,2
EMIDDLE (Average illuminance on the cooking surface) (lux)	140,4

External Dimensions

Width (mm)	600
Depth (mm)	500
Maximum Total Height (mm)	1080
Minimum Total Height (mm)	700
Outlet Diameter (mm)	150

Characteristics

Motor Quantity	1
Motor Model	A1000
Maximum Pressure (Pa)	473,39
Filter Technology	Aluminium mesh
Control Technology	PANEL ELECTRONICO DISPLAY DIGITAL
Booster	√
Power levels	3
Timer	√

Lighting

Light Model	ECOLED
Lighting Technology	LED

Installation

Minimum distance to an electric cooktop (mm)	550
Minimum distance to a gas cooktop (mm)	650
Charcoal Filter	√
Back Draught Shutter	Included

Electric Connection

Rated voltage (V)	220-240
-------------------	---------

Rated frequency (Hz)	50
Rated power input (W)	383
Protection against electric shock	Class I
Plug type	Type F

Accessories

Back Draught Shutter	02800706
----------------------	----------
