

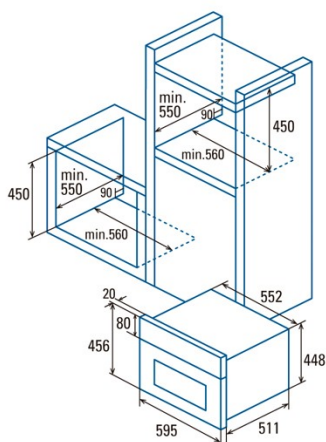

CMD 5008 X

Cod. 07003307

EAN 8422248067881



INFORMACIÓN GENERAL

EAN/UPC	8422248067881
Subfamily	Compact

Product fiche

Energy efficiency index (IEE)	97,2
Energy efficiency Class	A
Energy consumption in conventional mode [kWh/cycle]	0,7
Energy consumption in fan-forced mode [kWh/cycle]	0,71
Heat source	Electricity
Mass of the appliance [Kg]	30,4
Number of cavities	1
Cavity volume (L)	40

Dimensions

Width (mm)	456
Height (mm)	595
Depth (mm)	502
Built-in width (mm)	560
Built-in height (mm)	450
Built-in depth (mm)	550

Controls

Control type	Touch control
Display	LCD
Number of functions	8
Functions	Top_and_bottom_heating_with_fan;Tur heating;Bottom heating with fan;Double grill with fan;Defrosting;Top and bottom heating;Top heating;Light
Timer	Electronic
On/Off indicator	√
Thermostat indicator	√
Minimum temperature [°C]	50
Maximum temperature [°C]	250
Thermal probe	-

Characteristics

Cleaning	Aquasmart Manual
Enamel	Black
Drop down grill	-
Removable inner glass	-
Number of light bulbs	25
Light bulb power [W]	1
Number of door glasses	3
Door manual lock	-
Soft close	-
Cavity type	Flat
Side Racks	√
Levels	4
Telescopic guides	0,75
Convection fan	√

Security

Cooling fan	√
Overheating protection	√
Automatic safety shutdown	√
Pyrolysis door lock	-
Pyrolysis lock indicator	-

Electrical connection

Upper heating element power [W]	900
Lower heating element power [W]	1300

Turbo heating element power [W]	2300
Rated voltage (V)	220-240
Rated frequency (Hz)	50/60
Rated power input (W)	2380
Protection against electric shock	Class I
Power cord length (m)	1
Plug type	No plug

Accessories

Flat tray	-
Deep Tray	√
Steam tray	-
Grill	√
Inner grill	-
Telescopic guides	√
Tray Handle	-
Removable tank	-
Pizza Stone	-
Roast kit	-