

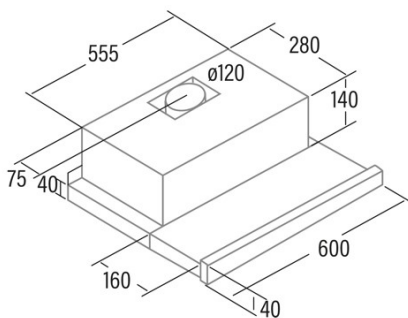

EXTENDER 600

Cod. 02017606

EAN 8422248110334



INFORMACIÓN GENERAL

EAN/UPC	8422248110334
Subfamily	Telescopic

Product fiche according to directives EU65/2014 - EN61591, EN60704-2-13, EN50564

AEC (Energy consumption per year) (kWh/año)	44,5
EEL class (Energy efficiency class)	C
FDE (Fluid dynamic efficiency)	11,9
FDE class (Fluid dynamic efficiency class)	E
LE (Light efficiency) (lux/W)	40
LE class (Light efficiency class)	A
GFE (Grease filtering efficiency)	68
GFE Class (Grease filtering efficiency class)	D
Normal mode airflow MIN (m3/h)	150
Normal mode airflow MAX (m3/h)	390
Normal mode acoustic power MIN (dB)	45,5
Normal mode acoustic power MAX (dB)	57

Integration directive EU 66/2014

f (Factor Increase in the time)	1,6
EEL (Energy efficiency Index)	78,2
QBEP (Maximum airflow point efficiency) (m3/h)	201,1
PBEP (Maximum pressure point efficiency) (Pa)	12,5
WBEP (Electrical power consumption at maximum efficiency) (W)	69
WL (Rated power lighting system) (W)	7
EMIDDLE (Average illuminance on the cooking surface) (lux)	252

External Dimensions

Width (mm)	600
Depth (mm)	440
Maximum Total Height (mm)	181
Outlet Diameter (mm)	120

Characteristics

Motor Quantity	1
Motor Model	TF2003
Maximum Pressure (Pa)	194
Filter Technology	Aluminium mesh
Control Technology	Mechanical rocker switch
Booster	-
Power levels	2
Timer	-
Filter Saturation Indicator	-
Charcoal Filter Change Indicator	-
Dimmer Function	-
Connectivity	-
Remote control	-
Display	-

Lighting

Light Model	ECOLED
Lighting Technology	LED

Installation

Minimum distance to an electric cooktop (mm)	556
Minimum distance to a gas cooktop (mm)	656

Electric Connection

Rated voltage (V)	220-240
Rated frequency (Hz)	50

Rated power input (W)	107
Protection against electric shock	Class I

Accessories

Active Charcoal Filter	02825267
Noiseless Flexible Duct	02800004
