

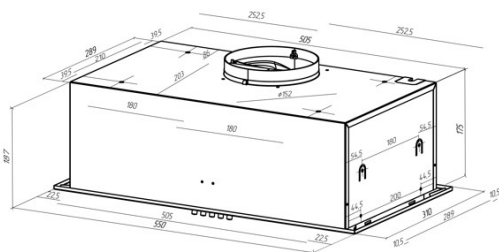

GCB 55 X

Cod. 02030300

EAN 8422248108454



INFORMACIÓN GENERAL

EAN/UPC	8422248108454
Subfamily	Insert

Product fiche according to directives EU65/2014 - EN61591, EN60704-2-13, EN50564

AEC (Energy consumption per year) (kWh/año)	54
EEl class (Energy efficiency class)	C
FDE (Fluid dynamic efficiency)	10,1
FDE class (Fluid dynamic efficiency class)	E
LE (Light efficiency) (lux/W)	30,4
LE class (Light efficiency class)	A
GFE (Grease filtering efficiency)	58,3
GFE Class (Grease filtering efficiency class)	E
Normal mode airflow MIN (m3/h)	282
Normal mode airflow MAX (m3/h)	371,1
Normal mode acustic power MIN (dB)	59
Normal mode acustic power MAX (dB)	65,9
Po (Off-mode power consumption) (W)	0

Integration directive EU 66/2014

f (Factor Increase in the time)	1,64
EEl (Energy efficiency Index)	83,6
QBEP (Maximum airflow point efficiency) (m3/h)	197,5
PBEP (Maximum pressure point efficiency) (Pa)	161
WBEP (Electrical power consumption at maximum efficiency) (W)	87,2
WL (Rated power lighting system) (W)	3
EMIDDLE (Average illuminance on the cooking surface) (lux)	91,2

External Dimensions

Width (mm)	550
Depth (mm)	310
Maximum Total Height (mm)	187
Minimum Total Height (mm)	187
Outlet Diameter (mm)	150, 125

Characteristics

Motor Quantity	1
Maximum Pressure (Pa)	226
Filter Technology	Aluminium mesh
Control Technology	Mechanical push button
Booster	-
Power levels	3
Timer	-
Filter Saturation Indicator	-
Charcoal Filter Change Indicator	-
Dimmer Function	-
Connectivity	No
Remote control	-
Display	-

Lighting

Light Model	CSLED
Lightning Technology	LED

Installation

Minimum distance to an electric cooktop (mm)	550
Minimum distance to a gas cooktop (mm)	650
Recirculation Option	√
Charcoal Filter	-
Back Draught Shutter	Included

Inner shield -

Electric Connection

Rated voltage (V)	220-240
Rated frequency (Hz)	50
Rated power input (W)	123
Protection against electric shock	Class I

Accessories

Active Charcoal Filter	02859500
Noiseless Flexible Duct	02893002
