

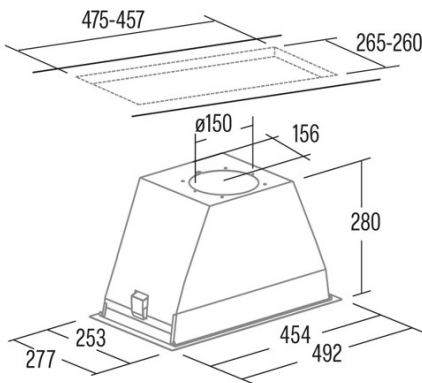

GL 45 X

Cod. 02030305

EAN 8422248077842



INFORMACIÓN GENERAL

EAN/UPC	8422248077842
Subfamily	Insert

Product fiche according to directives EU65/2014 - EN61591, EN60704-2-13, EN50564

AEC (Energy consumption per year) (kWh/año)	58,3
EEl class (Energy efficiency class)	A
FDE (Fluid dynamic efficiency)	30,2
FDE class (Fluid dynamic efficiency class)	A
LE class (Light efficiency class)	B
GFE (Grease filtering efficiency)	91,2
GFE Class (Grease filtering efficiency class)	B
Normal mode airflow MIN (m3/h)	0
Normal mode airflow MAX (m3/h)	600
Normal mode acustic power MIN (dB)	50
Normal mode acustic power MAX (dB)	65
Boost mode acustic power (dB)	67

Integration directive EU 66/2014

f (Factor Increase in the time)	0,9
EEl (Energy efficiency Index)	54,40000
PBEP (Maximum pressure point efficiency) (Pa)	405
WBEP (Electrical power consumption at maximum efficiency) (W)	159,8
WL (Rated power lighting system) (W)	7

External Dimensions

Width (mm)	492
Depth (mm)	Warranty Document
Minimum Total Height (mm)	280
Outlet Diameter (mm)	150, 125

Characteristics

Motor Quantity	1
Motor Model	BT3
Maximum Pressure (Pa)	450
Control Tecnology	Electronic Touch Control
Booster	457
Power levels	4
Timer	√
Filter Saturation Indicator	√
Charcoal Filter Change Indicator	-
Dimmer Function	320
Remote control	-
Display	Palletization Procedure

Lighting

Lightning Technology	Icons
----------------------	-------

Installation

Minimum distance to an electric cooktop (mm)	550
Minimum distance to a gas cooktop (mm)	650
Charcoal Filter	\$se
Back Draught Shutter	Insert
Inner shield	-

Electric Connection

Rated voltage (V)	220-240
Rated frequency (Hz)	50
Rated power input (W)	287
Plug type	Type C

Accessories

Upper Decorative Duct Extension	No
White Decorative Duct	No
Black Decorative Duct	No
Island Tube Enhancer	No
Back Draught Shutter	2832004
MAX PRO Metal Filter	No
Active Charcoal Filter	2859398
Noiseless Flexible Duct	2893002
Recirculating kit	No