

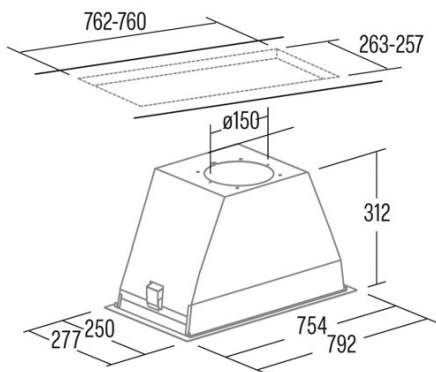

GL75 X

Cod. **02031302**

EAN **8422248190411**



INFORMACIÓN GENERAL

EAN/UPC	8422248190411
Subfamily	Insert

Product fiche according to directives EU65/2014 - EN61591, EN60704-2-13, EN50564

AEC (Energy consumption per year) (kWh/año)	583
EEL class (Energy efficiency class)	A
FDE (Fluid dynamic efficiency)	302
FDE class (Fluid dynamic efficiency class)	A
LE (Light efficiency) (lux/W)	243
LE class (Light efficiency class)	B
GFE (Grease filtering efficiency)	912
GFE Class (Grease filtering efficiency class)	B
Normal mode airflow MIN (m3/h)	340
Normal mode airflow MAX (m3/h)	600
Boost mode airflow (m3/h)	820
Normal mode acoustic power MIN (dB)	50
Normal mode acoustic power MAX (dB)	65
Boost mode acoustic power (dB)	67
Po (Off-mode power consumption) (W)	0,3
Ps (Stand-by power consumption) (W)	0

Integration directive EU 66/2014

f (Factor Increase in the time)	0,9
EEL (Energy efficiency Index)	544
QBEP (Maximum airflow point efficiency) (m3/h)	429,4
PBEP (Maximum pressure point efficiency) (Pa)	405
WBEP (Electrical power consumption at maximum efficiency) (W)	159,8
WL (Rated power lighting system) (W)	7
EMIDDLE (Average illuminance on the cooking surface) (lux)	170

External Dimensions

Width (mm)	792
Depth (mm)	277
Maximum Total Height (mm)	315
Minimum Total Height (mm)	315
Outlet Diameter (mm)	150, 125

Characteristics

Motor Quantity	1
Motor Model	BT3
Maximum Pressure (Pa)	450
Filter Technology	Aluminium mesh
Control Technology	Electronic Soft Touch
Booster	√
Power levels	4
Timer	√
Filter Saturation Indicator	√
Charcoal Filter Change Indicator	-
Dimmer Function	√
Connectivity	-
Remote control	-
Display	Display_grafico

Lighting

Light Model	ECOLED
Lighting Technology	LED

Installation

Minimum distance to an electric cooktop (mm)	550
--	-----

Minimum distance to a gas cooktop (mm)	650
Recirculation Option	√
Charcoal Filter	-
Back Draught Shutter	-
Inner shield	-

Electric Connection

Rated voltage (V)	220-240
Rated frequency (Hz)	50
Rated power input (W)	287
Protection against electric shock	Class II
Power cord length (m)	1,5
Plug type	Type C

Accessories

Back Draught Shutter	2832004
Active Charcoal Filter	2859398
Noiseless Flexible Duct	2893002
