

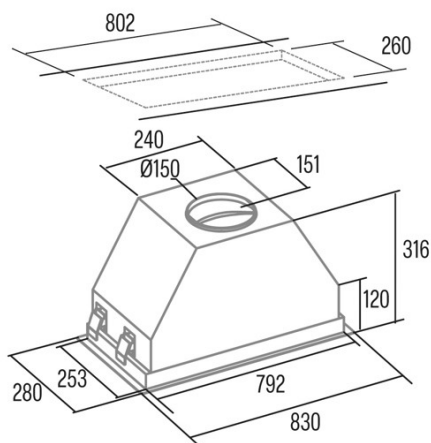

GCX 83 SD

Cod. 02031308

EAN 8422248103589

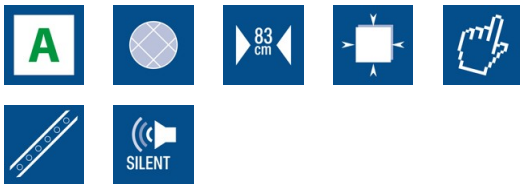

INFORMACIÓN GENERAL

EAN/UPC	8422248103589
Subfamily	Insert

Product fiche according to directives EU65/2014 - EN61591, EN60704-2-13, EN50564

AEC (Energy consumption per year) (kWh/año)	55
EEL class (Energy efficiency class)	A
FDE (Fluid dynamic efficiency)	30,2
FDE class (Fluid dynamic efficiency class)	A
LE (Light efficiency) (lux/W)	31
LE class (Light efficiency class)	A
GFE (Grease filtering efficiency)	91,2
GFE Class (Grease filtering efficiency class)	B
Normal mode airflow MIN (m3/h)	340
Normal mode airflow MAX (m3/h)	600
Boost mode airflow (m3/h)	750
Normal mode acoustic power MIN (dB)	50
Normal mode acoustic power MAX (dB)	65
Boost mode acoustic power (dB)	67
Po (Off-mode power consumption) (W)	0,3
Ps (Stand-by power consumption) (W)	0,3

Integration directive EU 66/2014

f (Factor Increase in the time)	0,9
EEL (Energy efficiency Index)	53
QBEP (Maximum airflow point efficiency) (m3/h)	429,4
PBEP (Maximum pressure point efficiency) (Pa)	405
WBEP (Electrical power consumption at maximum efficiency) (W)	159,8
WL (Rated power lighting system) (W)	3,5
EMIDDLE (Average illuminance on the cooking surface) (lux)	109

External Dimensions

Width (mm)	530
Depth (mm)	280
Maximum Total Height (mm)	316
Minimum Total Height (mm)	316
Outlet Diameter (mm)	150

Characteristics

Motor Quantity	1
Motor Model	BT3
Maximum Pressure (Pa)	450
Filter Technology	Aluminium mesh
Control Technology	Electronic Touch Control
Booster	√
Power levels	4
Timer	√
Filter Saturation Indicator	√
Charcoal Filter Change Indicator	-
Dimmer Function	√
Connectivity	-
Remote control	-
Display	Display_grafico

Lighting

Light Model	SSLED BICOLOR
Lightning Technology	LED

Installation

Minimum distance to an electric cooktop (mm)	550
--	-----

Minimum distance to a gas cooktop (mm)	650
Recirculation Option	√
Charcoal Filter	-
Back Draught Shutter	Included

Electric Connection

Rated voltage (V)	220-240
Rated frequency (Hz)	50
Rated power input (W)	283,5
Protection against electric shock	Class II
Power cord length (m)	1,5

Accessories

Upper Decorative Duct Extension	N_A
White Decorative Duct	N_A
Black Decorative Duct	N_A
Island Tube Enhancer	N_A
MAX PRO Metal Filter	N_A
Active Charcoal Filter	2859398
Noiseless Flexible Duct	2893002
Recirculating kit	No
