

TENTA 900 XGWH

Cod. **02189005**

EAN **8422248093729**

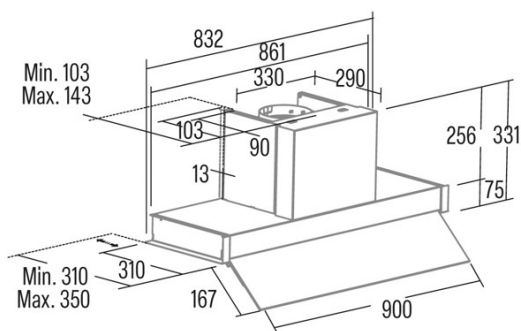

INFORMACIÓN GENERAL

EAN/UPC	8422248093729
Subfamily	Integrated

Product fiche according to directives EU65/2014 - EN61591, EN60704-2-13, EN50564

AEC (Energy consumption per year) (kWh/año)	24,7
EEl class (Energy efficiency class)	AP
FDE (Fluid dynamic efficiency)	37,5
FDE class (Fluid dynamic efficiency class)	A
LE (Light efficiency) (lux/W)	23,7
LE class (Light efficiency class)	B
GFE (Grease filtering efficiency)	62,7
GFE Class (Grease filtering efficiency class)	E
Normal mode airflow MIN (m3/h)	245
Normal mode airflow MAX (m3/h)	509,4
Boost mode airflow (m3/h)	765,3
Normal mode acoustic power MIN (dB)	46
Normal mode acoustic power MAX (dB)	63
Boost mode acoustic power (dB)	67
Po (Off-mode power consumption) (W)	0,49
Ps (Stand-by power consumption) (W)	0

Integration directive EU 66/2014

f (Factor Increase in the time)	0,7
EEl (Energy efficiency Index)	40,3
QBEP (Maximum airflow point efficiency) (m3/h)	346,6
PBEP (Maximum pressure point efficiency) (Pa)	298
WBEP (Electrical power consumption at maximum efficiency) (W)	76,6
WL (Rated power lighting system) (W)	7
EMIDDLE (Average illuminance on the cooking surface) (lux)	166

External Dimensions

Width (mm)	900
Depth (mm)	310
Maximum Total Height (mm)	331
Minimum Total Height (mm)	331
Outlet Diameter (mm)	150

Characteristics

Motor Quantity	1
Motor Model	BT4DC
Maximum Pressure (Pa)	357
Filter Technology	Aluminium mesh
Control Tecnology	Electronic Touch Control
Booster	√
Power levels	6
Timer	√
Filter Saturation Indicator	√
Charcoal Filter Change Indicator	-
Dimmer Function	√
Connectivity	√
Remote control	-
Display	Display_grafico

Lighting

Light Model	SSLED BICOLOR
Lightning Technology	LED

Installation

Minimum distance to an electric cooktop (mm)	550
--	-----

Minimum distance to a gas cooktop (mm)	650
Recirculation Option	√
Charcoal Filter	-
Back Draught Shutter	-
Inner shield	-

Electric Connection

Rated voltage (V)	220-240
Rated frequency (Hz)	50
Rated power input (W)	146
Protection against electric shock	Class I
Plug type	No plug

Accessories

Upper Decorative Duct Extension	No
White Decorative Duct	No
Black Decorative Duct	No
Island Tube Enhancer	No
Back Draught Shutter	2832008
MAX PRO Metal Filter	No
Active Charcoal Filter	2859399
Noiseless Flexible Duct	2893002
Recirculating kit	No
